

Spectrex SharpEye™ 40/40 Series

Flame Detectors



Safety instructions

⚠ WARNING

Physical access

Unauthorized personnel may potentially cause significant damage to and/or misconfiguration of end users' equipment. This could be intentional or unintentional and needs to be protected against.

Physical security is an important part of any security program and fundamental in protecting your system. Restrict physical access by unauthorized personnel to protect end users' assets. This is true for all systems used within the facility.

Contents

Models..... 3

Installing the detector..... 6

Special conditions for use..... 19

Declarations of Conformity.....21

Reference data..... 25

1 Models

The SharpEye™ 40/40 Flame Detectors are electro-optical devices designed to identify fire events, enabling alarm activation. The detectors are intended for indoor or outdoor use and can be used stand alone or connected to an alarm or automatic extinguishing system.

The SharpEye 40/40 series comprises the following detectors:

SharpEye 40/40C-I

The SharpEye 40/40C-I Multispectrum Quad-Sense™ Flame Detector detects hydrocarbon fuel and gas fires with enhanced performance, advanced long distance detection of hydrocarbon fires, fast detection in under five seconds, and strengthened reliability. The SharpEye 40/40C-I is based on proven triple infrared (IR3) technology, ensuring high sensitivity with superior immunity to false alarms.

SharpEye 40/40C-M

The SharpEye 40/40C-M Multispectrum Quad-Sense IR Flame Detector is specifically designed for the detection of hydrocarbon and hydrogen flames with enhanced performance, advanced long distance detection of hydrogen and hydrocarbon fires, fast detection in under five seconds, and strengthened reliability. The SharpEye 40/40C-M is based on proven triple IR (IR3) technology, ensuring high sensitivity with superior immunity to false alarms.

SharpEye 40/40C-LB

The SharpEye 40/40C-LB Dual Spectrum Ultraviolet (UV)/IR Flame Detector is designed to provide fast detection in under five seconds of a range of fires, such as hydrocarbon-based fuel and gas, hydroxyl, hydrogen, metal, and inorganic.

SharpEye 40/40C-L4B

The SharpEye 40/40C-L4B Dual Spectrum UV/IR Flame Detector is designed to provide fast detection in under five seconds of hydrocarbon-based fuel and gas fires.

SharpEye 40/40D-I

The SharpEye 40/40D-I Ultra Fast Multispectrum Quad-sense IR3 flame detector provides superior, longest distance detection of hydrocarbon fires at up to 300 ft (90 m), exceptional ultra-fast detection in under 50 msec, and unparalleled reliability. The SharpEye 40/40D-I is based on proven Triple IR (IR3) technology, ensuring highest sensitivity with best immunity to false alarms.

SharpEye 40/40D-M

The SharpEye 40/40D-M Multispectrum Quad-Sense IR Flame Detector provides superior, longest distance detection of hydrogen (at up to 165 ft [50 m]) and hydrocarbon (at up to 300 ft [90 m]) fires, exceptional ultra-fast detection in under 50 msec, and unparalleled reliability. The SharpEye 40/40D-M is designed to deal with the challenges of invisible fires based on proven IR3 technology, ensuring highest sensitivity with best immunity to false alarms.

SharpEye 40/40D-LB

The SharpEye 40/40D-LB Ultra Fast UV/IR Flame Detector can detect fire in under 20 msec and features a unique dual sensor with selectable UV and IR channels that can be used separately or combined. The detector is designed to detect a range of fires, such as hydrocarbon-based fuel and gas, hydroxyl, hydrogen, metal, and inorganic.

SharpEye 40/40D-L4B

The SharpEye 40/40D-L4B Ultra Fast UV/IR Flame Detector can detect fire in under 20 msec and features a unique dual sensor with selectable UV and IR channels that can be used separately or combined. The detector is designed to detect hydrocarbon-based fuel and gas fires.

Table 1-1: SharpEye 40/40 Series general technical specifications

Spectral response	Infrared and ultraviolet bands
Response time	Varies according to model, typically under 5 seconds
Field of view	Varies according to model, up to 100 degrees
Output	4-20 mA, relays, communication
Enclosure	Stainless steel 316 or aluminum polyurethane painted
Operating voltage	18-32 VDC
Relay contacts	2A/30 VDC
Over voltage category	2
Relative humidity	Non-condensing relative humidity up to 100%

Table 1-2: Typical current consumption

Typical current consumption	40/40C-I 40/40C-M	40/40C-LB 40/40C-L4B	40/40D-I 40/40D-M	40/40D-LB 40/40D-L4B
Normal power consumption without heater- mA (Watts)	60 (1.4)	90 (2.2)	60 (1.4)	90 (2.2)
Normal power consumption without heater with alarm - mA (Watts)	90 (2.2)	120 (2.9)	90 (2.2)	120 (2.9)
Low power heater with alarm - mA (Watts)	N/A	N/A	140 (3.4)	180 (4.3)
Standard power mode heater with alarm - mA (Watts)	310 (7.5)	320 (7.7)	280 (6.7)	320 (7.7)

NOTICE

- If the product is used outside of specified limits, this voids the product certification, and our company is not responsible for any incurred warranty expense.
- Do not open this product, except for the terminal compartment as listed in this document, under any circumstances.
- The detector is not field-repairable. Do not attempt to modify or repair the internal circuits or change their settings, as this will impair the system's performance and void the product warranty.
- Opening the attachment screws to dismantle the front part of the detector from remaining parts is restricted and voids the product warranty.

2 Installing the detector

Table 2-1: Required tools

Tool	Function
Hex key 1.5 mm	Fasten back cover security screw.
Hex key 6 mm	Adjust the tilt mount.
Hex key 10 mm	Affix the detector to the tilt mount.
Hex key ⅜-in	Attach protective cover to detector.
Flat screwdriver 6 mm	Connect ground terminal.
Flat screwdriver 2.5 mm	Connect wires to the terminal blocks.
Hex key ⅝-in	Stop plug ¾-in. NPT.
Open wrench 28 mm	Stop plug M25 only.

NOTICE

These are standard tools and are not supplied with the detector.

2.1 Mounting accessories

2.1.1 Tilt mount

The tilt mount (PN 877090) enables the detector to be mounted on flat wall surfaces.

Related information

[Attach detector to tilt mount](#)

2.1.2 Duct mount

The duct mount (PN 877670) allows flame detection in cases where the detector cannot be installed inside the area.

The duct mount limits the cone of vision of the installed detector to 70 degrees horizontal and vertical.

2.1.3 Pole mount

Use the pole mount to mount the detector on poles with the following diameters:

Table 2-2: Pole mount options

Pole diameter	Part number
2 in. (50.8 mm)	789260-2
3 in. (76.2 mm)	789260-1
4 in. (101.6 mm)	789260-3

For more instructions, refer to the [Pole Mount Manual](#).

2.2 Attach detector to tilt mount

Figure 2-1: Tilt mount

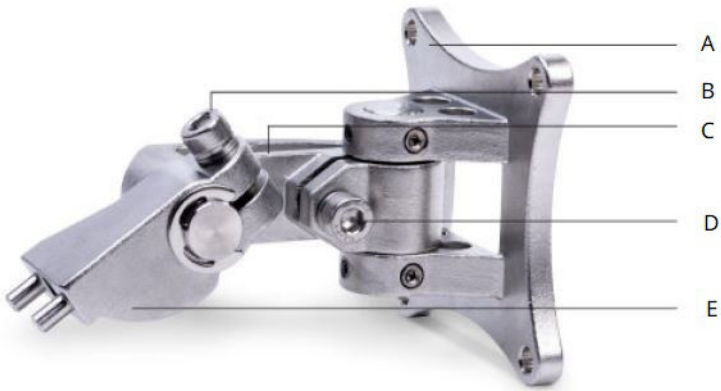

- A. *Tilt holding plate*
- B. *Horizontal locking screw*
- C. *Tilt mount*
- D. *Vertical locking screw*
- E. *Detector holding plate*

Figure 2-2: Tilt mount with dimensions

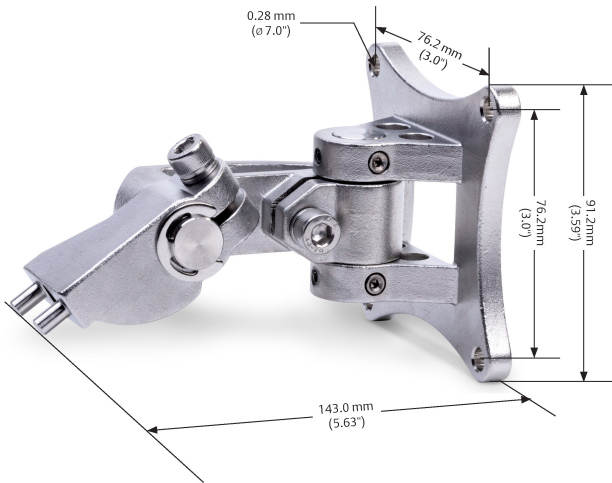

Procedure

1. Unpack the detector.
2. The device is provided with two plastic plugs (See [image](#) below). The stainless-steel stop plug used to seal the unused conduit will be included in the device.

Remember, seal the detector with the stainless-steel plug before use. Refrain from losing the plug in any case

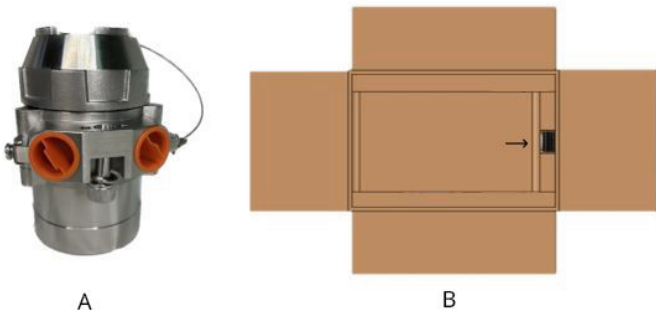

- A. Detector with two plastic plugs
- B. Product packaging with stainless-steel plug attachment

3. Insert location pins on the tilt mount into the openings on detector housing.

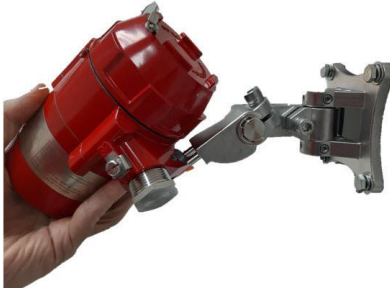

4. Thread the holding screw and tighten it.

Note

To change the detector field of view, release the horizontal and vertical locking screws.

5. Point the detector toward the protected area and ensure the view of the area is unobstructed.
6. Secure the detector in that position by tightening the locking screws on the tilt mount.
The detector is now correctly located, aligned, and ready to be connected to the system.

2.3 Open the back cover

Procedure

1. Loosen the back cover security screw.
-



A. Back cover security screw

B. Protective plug

2. Unscrew the back cover.
-

Note

The back cover is attached by a security cable.

3. Remove the protective plug.

2.4 Wire terminals and ground cable

NOTICE

Improper wiring may damage the detector.

Procedure

1. Connect the terminals according to [Table 2-3](#).
The terminal details are also on the inside back cover.

Figure 2-3: Terminal box



Table 2-3: Terminal box

Terminal	Function
T1	24 VDC (+)
T2	24 VDC (-)
T3	External built-in test (BIT) switch
T4	Fault relay - normally open (NO)
T5	Fault relay
T6	Fault relay - normally closed (NC)
T7	Alarm relay - NO
T8	Alarm relay
T9	Alarm relay - NC
T10	0-20 mA (+)
T11	0-20 mA (-)
T12	Alarm output (40/40D models)
T13	RS-485 (+)
T14	RS-485 (-)
T15	Accessory relay - normally open
T16	Accessory relay
T17	Accessory relay - normally closed

When the fault relay wiring option is NC, the relay contact is open in normal status (energized) and closed in fault status (de-energized).

When the fault relay wiring option is NO, the relay contact is closed in normal status (energized) and open in fault status (de-energized).

When the alarm/accessories relay wiring option is NC, the relay contact is closed in normal status (de-energized) and open in alarm status (energized).

When the alarm/accessories relay wiring option is NO, the relay contact is open in normal status (de-energized) and closed in alarm status (energized).

- 2. Use Figure 2-4, Figure 2-5, Figure 2-6, and Figure 2-7 for typical wiring configurations.

Figure 2-4: Typical wiring for four-wire controllers

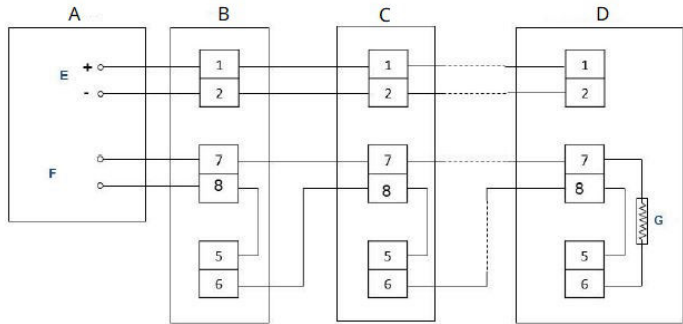

- A. Controller
- B. First detector
- C. Second detector
- D. Last detector
- E. Power supply
- F. Alarm loop
- G. End of line

Figure 2-5: Non-isolated sink (three wires)

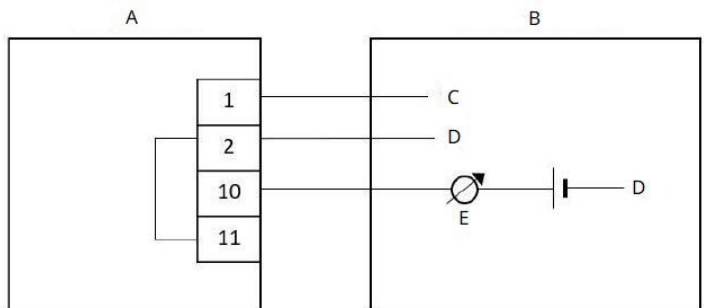

- A. Detector
- B. Controller
- C. Input power: 18 to 32 VDC
- D. Return
- E. 0-20 mA meter

Figure 2-6: Sink four-wire

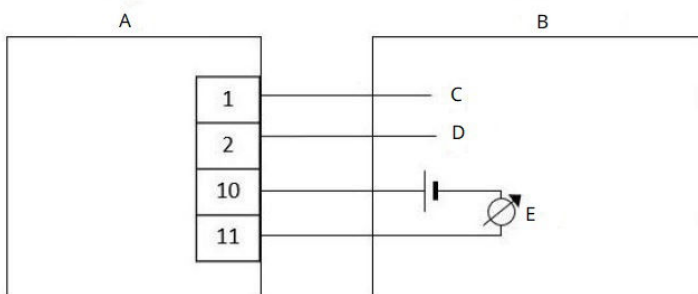

- A. Detector
- B. Controller
- C. Input power: 18 to 32 VDC
- D. Return
- E. 0-20 mA meter

Figure 2-7: Source three-wire

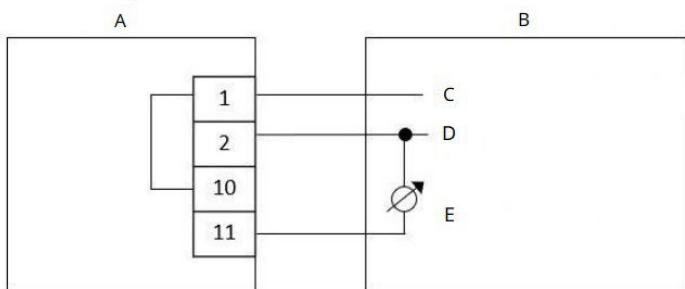

- A. Detector
- B. Controller
- C. Input power: 18-32 VDC
- D. Return
- E. 0-20 mA meter

Note

For additional configuration options, refer to the [SharpEye Next Generation 40/40 Series Flame Detectors](#).

3. Check the wires for secure mechanical connection and press them neatly against the terminal to prevent them from interfering while closing the back cover.
4. Close the terminal compartment by screwing the back cover on to the housing.

5. Tighten the back cover security screw.

Figure 2-8: Tilt mount

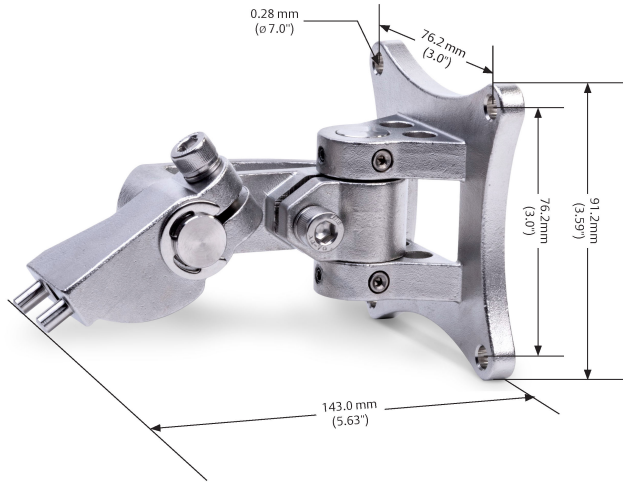

Figure 2-9: Closing security screw



- A. Back cover security screw
- B. Ground cable connection point

6. Connect the ground cable.

NOTICE

When the enclosed threaded plug is utilized in the conduit opening, it must be installed with a minimum thread engagement in order to comply with explosion-proof requirements. For straight threads, a minimum of seven threads must be engaged. For tapered threads, a minimum of five threads must be engaged.

Plug and seal the unused conduit connection with the provided conduit plug.

NOTICE

To comply with EMC directive 2014/30/EU and protect against interference caused by radio frequency interference (RFI) and electromagnetic interference (EMI), shield the cable to the detector and ground the detector.

2.5 Install the protective cover

NOTICE

Always install the protective cover with the detector.

The protective cover is available in ABS plastic or stainless steel.

Table 2-4: Protective cover

Material	Part number
ABS plastic	PN 877263
Stainless steel	PN 877163

Procedure

1. Place the protective cover on top of the detector.



2. Secure the protective cover by tightening the screw.

Note

When installing the stainless steel protective cover, the same installation instructions apply.

3 Special conditions for use

- Lids securing fasteners shall be property class A4 with a yield stress of 344 N/mm².
- Units may be painted or fitted with optional accessories; some of which are made of non-metallic material or have a non-metallic coating which could potentially generate an ignition-capable level of electrostatic charge under certain extreme conditions. Therefore, these units shall not be installed in a location where they may be subjected to external conditions (such as high-pressure steam) which might cause a build-up of electrostatic charges on the non-conducting surfaces. Additionally, cleaning of the equipment should be done only with a damp cloth.
- Temperature Increase at cable entry and branching point is 20.9 °C. This needs to be considered in the selection of cables for each ambient.
- Flameproof joints are not intended to be repaired The 40/40 Series Flame Detectors can be fitted with an un moulded (non-encapsulated), End of Line (EOL) Resistor. Such a resistor can only be fitted into the flameproof 'Ex d' compartment as indicated in the instructions. The EOL Resistor shall be rated at 1.56 kΩ, 1 W minimum.
- When the duct mount is fitted and the equipment is intended to be mounted to a heated/cooled air duct/process vessel, it must be verified that the temperature of the air duct/process vessel is not capable of heating or cooling any part of the equipment enclosure to a temperature outside the marked maximum ambient temperature range prior to switching the equipment on, when taking into account surrounding ambient temperature.
- The following table indicates the T-Class for each of the Ambient Temperature:

Model	Ambient (°C)		T-Class	T-Class
	Min	Max	Gas	Dust
40/40 D	-60	+45	T6	T85 °C
	-60	+60	T5	T100 °C
	-60	+85	T4	T120 °C
40/40 C	-40	+45	T6	T85 °C
	-40	+60	T5	T100 °C

Model	Ambient (°C)		T-Class	T-Class
	-40	+75	T4	T110 °C

To reduce the risk of ignition of a flammable or explosive atmosphere, strictly adhere to the following Caution and Warning statements:

⚠ WARNING

Do not open when energized.

Do not open when an explosive atmosphere is present.

Temperature Increase at cable entry and branching point is 20.9°C. This needs to be considered in the selection of cables for each ambient.

Potential electrostatic charging hazard – see instructions.

⚠ CAUTION

When the enclosed threaded plug is utilized in the conduit opening, it must be installed with a minimum thread engagement to comply with explosion-proof requirements. For straight threads, a minimum of seven threads must be engaged. For tapered threads, a minimum of five threads must be engaged. Plug and seal the unused conduit connection with the provided conduit plug.

4 Declarations of Conformity

Figure 4-1: SharpEye 40/40C

EU/UK_1410KC



Declaration of Conformity



We,

Rosemount Inc.
6021 Innovation Blvd
Shakopee, MN 55379
USA

declare under our sole responsibility that the product,

Spectrex SharpEye 40/40C Flame Detector

<p>Authorized Representative in Europe:</p> <p>Emerson S.R.L., company No. J12/88/2006, Emerson 4 street, Parcul Industrial Tetarom II, Cluj-Napoca 400638, Romania</p> <p>Regulatory Compliance Shared Services Department Email: europesproductcompliance@emerson.com Phone: +40 374 132 035</p>	<p>For product compliance destination sales questions in Great Britain, contact the Authorized Representative:</p> <p>Emerson Process Management Limited at ukproductcompliance@emerson.com or +44 11 6282 23 64, Regulatory Compliance Department.</p> <p>Emerson Process Management Limited, Company No 00671801, Meridian East, Leicester LE19 1UX, United Kingdom</p>
--	--

to which this declaration relates, is in conformity with:

- the relevant statutory requirements of Great Britain, including the latest amendments
- the provisions of the European Union Directives, including the latest amendments

 July 19, 2023
(signature & date of issue)

Mark Lee | VP Global Quality | Boulder, Colorado USA
(name) (function) (place of issue)

<p>ATEX Notified Body for EU Type Examination Certificate: CSA Group Netherlands B.V. [Notified Body Number: 2813] Utrechtseweg 310 6812 AR ARNHEM Netherlands</p> <p>ATEX Notified Body for Quality Assurance: SGS Fimko Oy [Notified Body Number: 0598] Takomitie 8 00380 Helsinki Finland</p>	<p>UK Conformity Assessment Body for UK Type Examination Certificate: CSA Group Testing UK Ltd [Approved Body Number: 0518] Unit 6 Hawarden Industrial Park, Hawarden, CH5 3US United Kingdom</p> <p>UK Approved Body for Quality Assurance: SGS Baseefa Ltd. [Approved Body Number: 1180] Rockhead Business Park, Staden Lane Buxton, Derbyshire. SK17 9RZ United Kingdom</p>
--	--

Quick Start Guide

21

EU/UK_1410KC



Declaration of Conformity

ATEX Directive (2014/34/EU)

CSAne 20ATEX1249X

Ex II 2 G D

Ex db eb IIC T6...T4 Gb
Ex tb IIIC T85°C...110°C Db
T6 (Tamb = -40°C to 45°C)
T5 (Tamb = -40°C to 60°C)
T4 (Tamb = -40°C to 75°C)

Harmonized Standards:

- EN IEC 60079-0:2018/AC:2020
- EN 60079-1:2014/AC:2018
- EN 60079-7:2015/A1:2018
- EN 60079-31:2014

EMC Directive (2014/30/EU)

Harmonized Standards:

- EN 50130-4:2011
- EN 61000-6-3:2007+A1:2011+AC:2012

RoHS Directive (Amended 2015/863/EU)

Harmonized Standards:

- EN IEC 63000:2018

Construction Products Directive-CPR (305/2011/EU)

Harmonized Standards:

- EN54-10:2002+A1:2005

Equipment and Protective Systems Intended for use in Potentially Explosive Atmospheres Regulations 2016 (S.I. 2016/1107)

CSAE 21UKEX1177X

Ex II 2 G D

Ex db eb IIC T6...T4 Gb
Ex tb IIIC T85°C...110°C Db
T6 (Tamb = -40°C to 45°C)
T5 (Tamb = -40°C to 60°C)
T4 (Tamb = -40°C to 75°C)

Designated Standards:

- EN IEC 60079-0:2018,
- EN 60079-1:2014
- EN 60079-7:2015+A1:2018
- EN 60079-31:2014

Electromagnetic Compatibility Regulations 2016 (S.I. 2016/1091)

Designated Standards:

- EN 50130-4:2011
- EN 61000-6-3:2007+A1:2011+AC:2012

Restriction of the Use of Certain Hazardous Substances in Electrical and Electronic Equipment Regulations 2012 (S.I. 2012/3032)

Designated Standards:

- EN IEC 63000:2018

Figure 4-2: SharpEye 40/40D

EU/UK_1400KE



Declaration of Conformity



We,

Rosemount Inc.
6021 Innovation Blvd
Shakopee, MN 55379
USA

declare under our sole responsibility that the product,

Spectrex SharpEye™ 40/40D Flame Detector

Authorized Representative in Europe:

Emerson S.R.L., company No. J12/88/2006,
Emerson 4 street, Parcul Industrial
Tetarom II, Cluj-Napoca 400638, Romania

Regulatory Compliance Shared Services
Department
Email: europesproductcompliance@emerson.com
Phone: +40 374 132 035

For product compliance destination sales questions in Great Britain, contact Authorized Representative:

ukproductcompliance@emerson.com or
+44 11 6282 23 64, Regulatory Compliance Department.

Emerson Process Management Limited,
company No 00671801, Meridian East,
Leicester LE19 1UX, United Kingdom

to which this declaration relates, is in conformity with:

- the relevant statutory requirements of Great Britain, including the latest amendments
- the provisions of the European Union Directives, including the latest amendments



July 19, 2023
(signature & date of issue)

Mark Lee	VP Global Quality	Boulder, Colorado USA
(name)	(function)	(place of issue)

ATEX Notified Body for EU Type Examination Certificate:
CSA Group Netherlands B.V. [Notified Body Number: 2813]
Ulrechtseweg 310
6812 AR ARNHEM
Netherlands

ATEX Notified Body for Quality Assurance:
SGS Fimko Oy [Notified Body Number: 0598]
Takomitie 8
00380 Helsinki
Finland

DNV Notified Body for Marine Equipment Directive:
DNV GL SE [Notified Body number: 0098]
Brooktorikal 18
20457 Hamburg
Germany

UK Conformity Assessment Body for UK Type Examination Certificate:
CSA Group Testing UK Ltd [Approved Body Number: 0518]
Unit 6 Hawarden Industrial Park, Hawarden, CH5 3US
United Kingdom

UK Approved Body for Quality Assurance:
SGS Baseefa Ltd. [Approved Body Number: 1180]
Rockhead Business Park, Staden Lane
Buxton, Derbyshire. SK17 9RZ
United Kingdom

DNV Approved Body for Marine Equipment Regulations:
DNV UK Ltd. [Approved Body number: 0097]
30 Stamford Street
Vivo Building
London, SE1 9LQ

EU/UK_1400KE



Declaration of Conformity



ATEX Directive (2014/34/EU)
CSAne 20ATEX1249X

Ex II 2 G D
Ex db eb IIC T6...T4 Gb
Ex Ib IIC T85°C...120°C Db
T6 (Tamb = -60°C to 45°C)
T5 (Tamb = -60°C to 60°C)
T4 (Tamb = -60°C to 85°C)

Harmonized Standards:
EN IEC 60079-0:2018/AC:2020
EN 60079-1:2014/AC:2018
EN 60079-7:2015/A1:2018
EN 60079-31:2014

EMC Directive (2014/30/EU)
Harmonized Standards:
EN 50130-4:2011
EN 61000-6-3:2007+A1:2011+AC:2012

RHS Directive (Amended 2015/863/EU)
Harmonized Standards:
EN IEC 63000:2018

Marine Equipment Directive (2014/90/EU)
Amended by implementing regulation 2022/1157*
MED/3.51e
EN 54-10:2002 incl. A1:2005
IEC 60392-504:2016, IEC 60533:2015
SOLAS 74 Reg. II-2/7
IMO Res.MSC.36(63)-(1994 HSC Code) 7
IMO Res.MSC.97(73)-(2000 HSC Code) 7
IMO Res.MSC.98(73)-(FSS Code) 9
IMO Res. MSC. 391(95)-(IGF Code)11
IMO MSC.1/Circ.1242



*EC Type Examination Model B Certification No. MEDB000078F expires 25th May 2026 plus EC Type D Certification of Conformity No. MEDD00001WT expires 2nd July 2024 issued by the Notified Body: DNV
Notification Body No.: 0098

Construction Products Directive-CPR (305/2011/EU)
Harmonized Standards:
EN54-10:2002+A1:2005

Equipment and Protective Systems intended for use in Potentially Explosive Atmospheres Regulations 2016 (S.I. 2016/1197)
CSAE 21UKEX1177X

Ex II 2 G D
Ex db eb IIC T6...T4 Gb
Ex Ib IIC T85°C...120°C Db
T6 (Tamb = -60°C to 45°C)
T5 (Tamb = -60°C to 60°C)
T4 (Tamb = -60°C to 85°C)

Designated Standards:
EN IEC 60079-0:2018
EN 60079-1:2014
EN 60079-7:2015+A1:2018
EN 60079-31:2014

Electromagnetic Compatibility Regulations 2016 (S.I. 2016/1091)
Designated Standards:
EN 50130-4:2011
EN 61000-6-3:2007+A1:2011+AC:2012

Restriction of the Use of Certain Hazardous Substances in Electrical and Electronic Equipment Regulations 2012 (S.I. 2012/3032)
Designated Standards:
EN IEC 63000:2018

Marine Equipment Regulations (2016 SI 2016/1026)
MSN 1874 Amendment 6, Item No. UK/3.51e,
SOLAS 74 as amended, Reg. II-2/7 & X/3 1994 HSC Code 7
2000 HSC Code 7
FSS Code 9
IGF Code 11
IMO MSC.1/Circ.1242

 Type Examination Model B Certification No. MERB000078F expires 24th May 2026 plus Model D QS-Certificate of Assessment No. MERD00001WT expires 2nd July 2024 issued by the Approved Body: DNV
Approved Body No.: 0097

5 Reference data

To view current SharpEye 40/40 ordering information, specifications, and drawings:

Procedure

1. Go to <https://www.spectrex.net/en-us/flame-gas-detectors/flame-detectors/sharpeye-40-40-next-generation-series-flame-detectors>.
2. Select the appropriate flame detector.
3. For installation drawings, click *Drawings & Schematics* and select the appropriate document.
4. For ordering information, specifications, and dimensional drawings, click *Data Sheets & Bulletins* and select the appropriate product data sheet.



Quick Start Guide
00925-0200-9975, Rev. AB
August 2023

For more information: [Emerson.com/global](https://www.emerson.com/global)

©2023 Emerson. All rights reserved.

Spectrex is a mark of one of the Emerson family of companies. All other marks are the property of their respective owners.

