

SharpEye™

Model 20/20MPI Mini Triple IR (IR3) Flame Detector User and Maintenance Manual



Document ref: TM 768200, Rev. (5), April 2017



8200 Market Blvd, Chanhassen, MN 55317, USA
Phone: +1 (973) 239 8398 Fax: +1 (973) 239 7614
Website: www.spectrex.net; Email: spectrex@spectrex.net

Legal Notice

The SPECTREX SharpEye Optical Flame Detector described in this document is the property of Rosemount.

No part of the hardware, software or documentation may be reproduced, transmitted, transcribed, stored in a retrieval system, or translated into any language or computer language, in any form or by any means, without prior written permission of Rosemount.

While great efforts have been made to assure the accuracy and clarity of this document, Rosemount assumes no liability resulting from any omissions in this document, or from misuse of the information obtained herein. The information in this document has been carefully checked and is believed to be entirely reliable with all of the necessary information included. Rosemount reserves the right to make changes to any products described herein to improve reliability, function, or design, and reserves the right to revise this document and make changes from time to time in content hereof with no obligation to notify any persons of revisions or changes. Rosemount does not assume any liability arising out of the application or any use of any product or circuit described herein; neither does it convey license under its patent rights or the rights of others.



Warning: This manual should be carefully read by all individuals who have or will have responsibility for using, maintaining or servicing the product.

The detector is not field-repairable due to the meticulous alignment and calibration of the sensors and the respective circuits. Do not attempt to modify or repair the internal circuits or change their settings, as this will impair the system's performance and void the SPECTREX Product warranty.

Release History

Rev	Date	Revision History	Prepared by	Approved by
2	June 2013	Second Release	Ian Buchanan	Eric Zinn
3	September 2013	Third Release	Ian Buchanan	Eric Zinn
4	September 2014	Fourth Release	Ian Buchanan	Eric Zinn
5	April 2017	Fifth Release	Jay Cooley	Shaul Serero

Table of Contents

Model 20/20MPI Mini Triple IR (IR3) Flame Detector	i
Legal Notice.....	iii
Release History	iv
About this Guide.....	10
Abbreviations and Acronyms	11
1 Introduction	13
1.1 Product Overview	13
2 Technical Description	15
2.1 Features	15
2.2 Principles of Operation.....	15
2.2.1 Hydrocarbon Fire Detection	15
2.2.2 Identifying the CO ₂ Peak.....	16
2.2.3 Limitations of IR-IR Flame Detectors	16
2.2.4 Advantages of IR3 Technology.....	16
2.2.5 Modbus RS-485	17
2.2.6 Types and Models	17
3 Performance	19
3.1 Detection Sensitivity	19
3.1.1 Standard Fire	19
3.1.2 Sensitivity Ranges	19
3.1.3 Other Fuels	20
3.2 Cone of Vision	21
3.3 False Alarms Prevention.....	22
4 Operation	25
4.1 Visual Indications.....	25
4.2 Output Signals.....	26
4.2.1 Optional Latching.....	27
4.2.2 Built-In-Test.....	27
4.3 Detector Mode Setup	28
4.3.1 Detector Setting	28
4.3.2 Detector Functions	28
4.3.3 Detector Default Setup	30
4.4 Built-In-Test.....	30
4.4.1 General	30

4.4.2	Principles	30
4.4.3	Automatic BIT	31
5	Technical Specifications.....	33
5.1	Electrical Specifications.....	33
5.2	Approvals.....	34
5.2.1	EN54-10	34
5.2.2	FM	34
5.3	Mechanical Specifications	34
5.4	Environmental Specifications	35
6	Installation Instructions.....	37
6.1	Scope.....	37
6.2	General Considerations	37
6.3	Preparations for Installation	38
6.4	Detector and Tilt Mount Installation.....	39
6.5	Detector Wiring	42
6.6	Wiring Function.....	42
6.7	Protective Cover Installation.....	43
6.8	Operation Mode	44
6.8.1	Programmable Function	44
6.8.2	Address	44
6.8.3	Alarm Delay	44
7	Operating Instructions	45
7.1	Power Up	45
7.2	Reset.....	46
7.3	Functional Testing.....	46
7.3.1	Testing with Flame Simulator Model FS-1100	46
7.4	Safety Precautions	47
8	Maintenance Instructions	49
8.1	Maintenance Instrumentation and Personnel	49
8.2	Preventive Maintenance Procedures.....	49
8.3	Periodic Maintenance Procedures	50
8.3.1	Power-Up Procedure.....	50
8.3.2	Functional Test Procedure	50
8.4	Maintenance Records.....	50
8.5	Troubleshooting	50
8.5.1	Fault Indication	50

8.5.2	False Alarm or Warning Indication.....	51
8.5.3	RS-485 Communications Network	51
Appendix		53
A Typical Wiring Configurations		55
A.1	Wiring Terminal 20/20MPI-R	55
A.2	Wiring Terminal 20/20MPI-M	56
B Flame Simulator FS-1100		59
B.1	Description.....	59
B.2	Ordering Information.....	60
B.3	Unpacking	60
B.4	Operating Instructions	61
B.5	Range.....	62
B.6	Charging the Battery	62
B.7	Battery Replacement	63
B.8	Technical Specifications	64
Technical Support.....		66

List of Figures

Figure 1: Flame Detector Assembly - Outline Drawing.....	17
Figure 2: Horizontal and Vertical Fields of View	21
Figure 3: Indicator LEDs	25
Figure 4: Tilt Mount Assembly - Outline Drawing	40
Figure 5: IR3 Detector and Tilt Mount Assembly	41
Figure 6: Protective Cover	43
Figure 7: Wiring Terminal 20/20MPI-R	55
Figure 8: Wiring Terminal 20/20MPI-M.....	56
Figure 9: RS-485 Networking.....	56
Figure 10: 0–20mA Source (3-Wire) - Model 20/20MPI-M	57
Figure 11: Typical Wiring for 4 Wire Controllers – Model 20/20MPI-R.....	57
Figure 12: Flame Simulator	59
Figure 13: Mini IR3 Detector Target Point.....	61
Figure 14: Flame Simulator Battery Replacement	62

List of Tables

Table 1: Alarm Response Time versus Range	19
Table 2: Response Sensitivity Ranges	20
Table 3: Immunity to False Alarm Sources	22
Table 4: Welding Immunity Distance	23
Table 5: 20/20MPI Status.....	26
Table 6: 20/20MPI Output Signals.....	26
Table 7: Detector State with Output Signals	27
Table 8: Time Delay	29
Table 9: Function Setup	29
Table 10: Default function set up	30
Table 11: Contact Ratings	33
Table 12: 0–20mA Current Output	33
Table 13: Detector Default Setup	44
Table 14: Sensitivity Ranges.....	62
Table 15: Immunity Tests	64
Table 16: Emission Tests.....	64

About this Guide

This guide describes the SharpEye Model 20/20MPI Mini Triple IR (IR3) Flame Detector and its features, and provides instructions on how to install, operate, and maintain the detector.

This guide includes the following chapters and appendices:

- **Chapter 1, Introduction**, provides a general introduction and overview of the product.
- **Chapter 2, Technical Description**, describes the detector's features and principles of operation.
- **Chapter 3, Performance**, describes the detector's detection sensitivity and capabilities.
- **Chapter 4, Operation**, describes the detector's operation modes, user interface, and indications.
- **Chapter 5, Technical Specifications**, lists the detector's electrical, mechanical, and environmental specifications.
- **Chapter 6, Installation Instructions**, describes preparations for installation, wiring, and mode settings.
- **Chapter 7, Operating Instructions**, shows how to power-up and test the detector.
- **Chapter 8, Maintenance and troubleshooting**, describes basic maintenance procedures, and support procedures.
- **Appendix A, Typical Wiring Configurations**, lists the wiring instructions for connecting the detector, and provides examples of typical wiring configurations.
- **Appendix B, Long Range IR3 Flame Simulator**, describes the flame simulator that can be specifically used with SharpEye IR3 flame detectors.

Abbreviations and Acronyms

Abbreviation	Meaning
ATEX	Atmosphere Explosives
AWG	American Wire Gauge
BIT	Built-In-Test
EMC	Electromagnetic Compatibility
EOL	End of Line
FOV	Field of View
IAD	Immune at Any Distance
IECEX	International Electrotechnical Commission Explosion
IPA	Isopropyl Alcohol
IR	Infrared
JP5	Jet Fuel
Latched	Refers to relays remaining in the On state even after the On condition has been removed
LED	Light Emitting Diode
LPG	Liquefied Petroleum Gas
mA	Milliamps (0.001 amps)
MODBUS	Master-slave messaging structure
N.C.	Normally Closed
N.O.	Normally Open
N/A	Not Applicable
NFPA	National Fire Protection Association
NPT	National Pipe Thread
VAC	Volts Alternating Current

1 Introduction

➤ **In this chapter...**

Product Overview

page 13

1.1 Product Overview

The SPECTREX Model 20/20MPI is a new version of the triple IR spectrum flame detector designed to provide maximum fire protection. It uses innovative technology of advanced digital signal processing to analyze the dynamic characteristics of fire. Three sensitive IR channels process the signals. Detection performance is controlled by a microprocessor and easily adapted to all environments, applications, and requirements. The result is a unique and superior flame detector, which provides excellent detection sensitivity together with extreme immunity to false alarms.

To use the host software and to change the required functions, refer to *Manual TM768050* for instructions.

2 Technical Description

➤ **In this chapter...**

<i>Features</i>	<i>page 15</i>
<i>Principles of Operation</i>	<i>page 15</i>

2.1 Features

The SharpEye Model 20/20MPI Mini Triple IR (IR3) Flame Detector includes the following features:

- **Detection Range:** up to 140ft/43m for a 1ft²/0.1m² n-heptane pan fire
- **Ultra High Immunity to False Alarms** (see *False Alarms Prevention*, page 22)
- **Advanced Digital Processing of the Dynamic Characteristics of Fire:** Flickering, Threshold correlation, and Ratio
- **3 Separate IR Channels:** Between 3–5 microns
- **Field Programmable Sensitivity:** 4 ranges
- **2 Response Levels:** Warning and Detection
- **Solar Blind**
- **Microprocessor Based:** Digital signal processing
- **Built-In-Test (BIT):** Manual and Automatic
- **2 Options of Electrical Interface:**
 - 20/20MPI-R: Dry contact relays
 - 20/20MPI-M: 0–20mA output (stepped)
- **Functional Approvals:**
 - EN54-10 approved per VdS
 - FM approved per FM3260

2.2 Principles of Operation

2.2.1 Hydrocarbon Fire Detection

The triple IR flame detector detects all conceivable types of hydrocarbon fires, i.e. any fire which emits CO₂.

2.2.2 Identifying the CO₂ Peak

The hydrocarbon fire is characterized by a typical radiation emission. The CO₂ peak emits intense radiation in the spectral band between 4.2–4.5μ and weaker radiation intensity outside this spectral band.

2.2.3 Limitations of IR-IR Flame Detectors

CO₂ in the atmosphere attenuates the radiation in this spectral band. (Absorption and emission of radiation always occur in the same band.) As a result, the greater the distance between the detector and the fire, the weaker the intensity of the radiation reaching the detector is (i.e. the CO₂ attenuation increases). This phenomenon explains the limitations of the existing IR-IR flame detectors in the market:

- Detection distance is restricted to 33ft/10m only.
- Their immunity to false alarm sources is limited.

2.2.4 Advantages of IR3 Technology

To overcome these limitations, SPECTREX devised an innovative concept of utilizing an additional detection channel. Three channels collect more data from the environment, giving analysis which is more accurate and better performance.

After careful investigation, 3 channels were selected which, when operating jointly, provide optimal fire detection characteristics:

- **Channel 1:** 4.2–4.6μ
Fire - the CO₂ peak
- **Channel 2:** 4.0–4.2μ
Eliminates false alarms from high temperature sources
- **Channel 3:** 4.8–5.2μ
Eliminates false alarms from flickering of background radiation

Most IR sources which create misleading IR alarm stimuli, including the sun, incandescent and halogen lamps, electric arc discharges, electrical heaters, etc., do not possess this unique spectral signature of fire.

The IR sensors of the detector respond only to flickering of radiation signals. The signals are compared to a predetermined threshold. Processing of the results from the 3 IR channels is performed by the board microprocessor. The result is a much greater detection distance and a highly increased ability to distinguish between fire and false alarms.

This sophisticated technology surpasses all other existing flame detection techniques on the market today.

Note: This unique flame analysis capability (patent pending) has been incorporated into the Triple-IR fire detector manufactured by SPECTREX. The result is a unique flame detector which does not produce false alarms, and at the same time, provides detection over greatly increased distances.

2.2.5 Modbus RS-485

For more advanced communication, the 20/20MPI has an RS-485 Modbus compatible output that provides data communications from a network (up to 247 detectors) to a host computer on universal controller, for central monitoring. This feature enables easy maintenance, and local or remote diagnostic tools.

2.2.6 Types and Models

The 20/20MPI has 2 models:

- 20/20MPI-R: Relay output
- 20/20MPI-M: 0–20mA output (stepped)

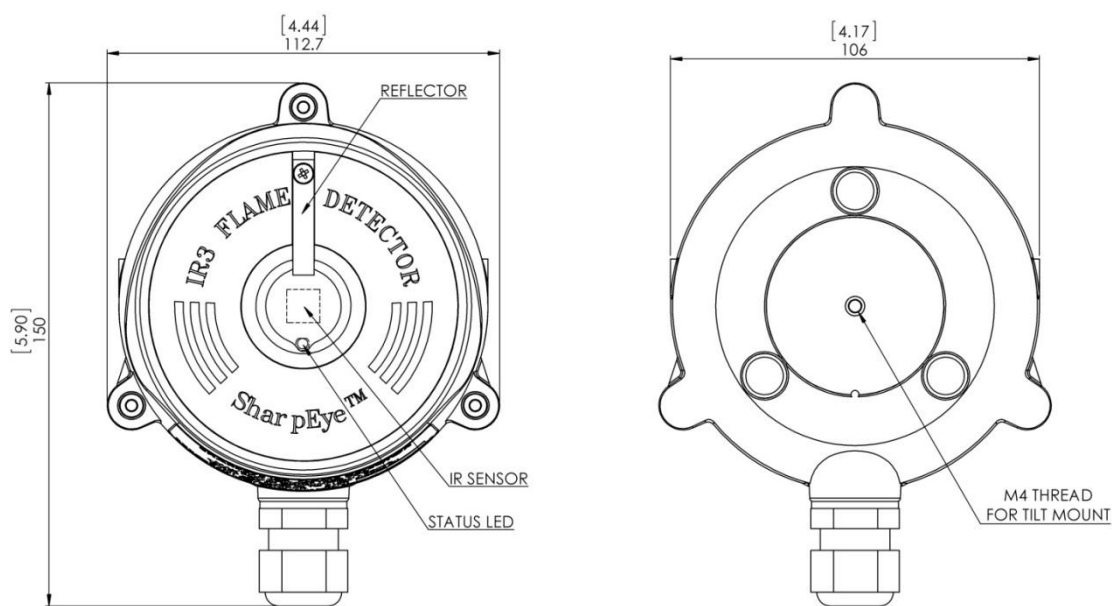

Figure 1: Flame Detector Assembly - Outline Drawing

3 Performance

➤ **In this chapter...**

<i>Detection Sensitivity</i>	<i>page 19</i>
<i>Cone of Vision</i>	<i>page 21</i>
<i>False Alarms Prevention</i>	<i>page 22</i>

3.1 Detection Sensitivity

Detection sensitivity is the maximum distance at which the detector will reliably detect a specific size of fire and typical type of fuel (standard fire).

3.1.1 Standard Fire

A standard fire is defined as a 1ft²/0.1m² gasoline pan fire with maximum wind speed of 6.5ft/sec / 2m/sec.

3.1.2 Sensitivity Ranges

The detector has 4 user-selectable sensitivity ranges. For each range there are 2 response levels.

- Warning (pre-alarm)
- Alarm

The detection distance, for the warning level, is approximately 10% higher than the alarm distance. Alarm response times for a standard fire at a specified range are shown in Table 1.

Table 1: Alarm Response Time versus Range

	10	20	30	40
Sensitivity Range (ft/m)	33/10	65/20	100/30	140/43
Response Time (sec)	5	8	10	10

For some typical ambient conditions the Zeta parameter, as defined in NFPA 72 for the detector, is 0.005 (1/meter).

Note: Zeta parameters may vary significantly with changes in temperature, air pressure, humidity, visibility conditions, etc.

3.1.3 Other Fuels

The detector reacts to other types of fires as shown in Table 2:

Table 2: Response Sensitivity Ranges

Type of Fuel	20/20MPI-R (ft/m)	Type of Fuel
Gasoline	140/43	100%
N-Heptane	140/43	100%
Alcohol 95%	100/30	70%
JP5	100/30	70%
Kerosene	100/30	70%
Diesel Fuel	100/30	70%
Methane*	39/12	28%
IPA	115/35	80%
Methanol	98/30	70%
LPG*	39/12	28%
Polypropylene	49/15	35%
Paper	49/15	35%

* 0.5m plume fire

Pan Fire Size: 1ft²/0.1m²

Maximum Wind Speed: 6.5ft/sec / 2m/sec

Maximum Response Time: 10sec

3.2 Cone of Vision

- Horizontal: 100°
- Vertical: 90°

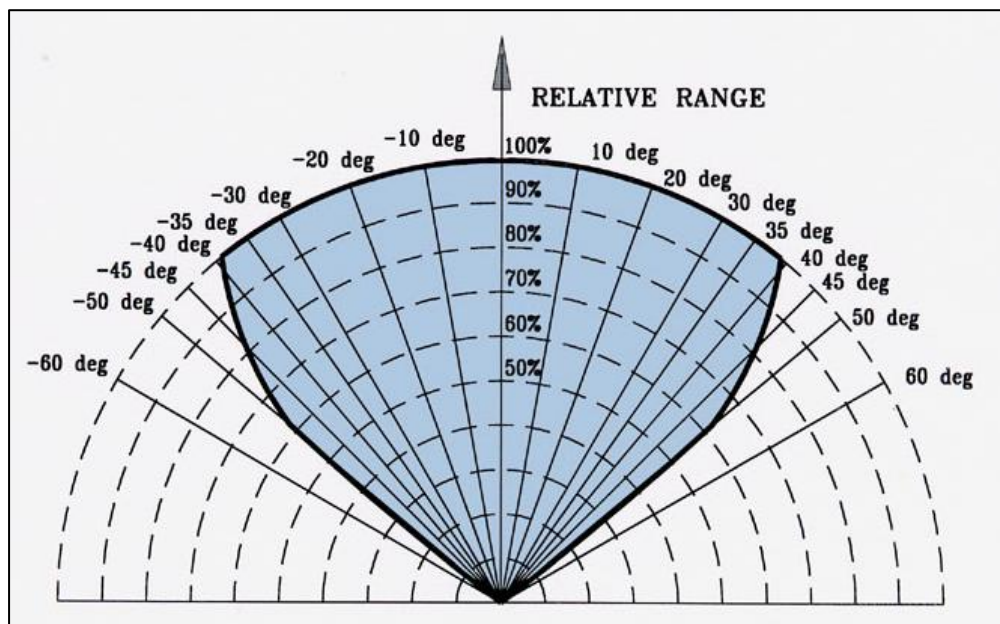

Figure 2: Horizontal and Vertical Fields of View

Note: Due to the reflector, there is a reduction in the cone of vision of 10° in the area of 5° around the reflector.

3.3 False Alarms Prevention

The detector does not provide an alarm or a warning signal as a reaction to the radiation sources specified in Table 3.

Table 3: Immunity to False Alarm Sources

Radiation Source	Immunity Distance (ft/m)
Sunlight	IAD
Indirect or reflected sunlight	IAD
Incandescent frosted glass light, 100W	IAD
Incandescent clear glass light, rough service, 100W	IAD
Fluorescent light with white enamel reflector, standard office or shop, 40W (or 2 20W)	IAD
Electric arc [12mm / 15/32" gap at 4000V alternating current, 60Hz]	IAD
Arc welding [4mm / 5/32" rod; 240A]	See Table 4
Ambient light extremes (darkness to bright light with snow, water, rain, desert glare, and fog)	IAD
Bright colored clothing, including red and safety orange.	IAD
Electronic flash (180 watt-seconds minimum output)	IAD
Movie light, 625W quartz DWY lamp (Sylvania S.G.-55 or equivalent)	6.5/2
Flashlight (MX 991/U)	IAD
Radiation heater, 1500W	IAD
Radiation heater, 1000W with fan	IAD
Quartz lamp, 1000W	10/3
Mercury vapor lamp	IAD
Grinding metal	IAD
Lit cigar	1/0.3
Lit cigarette	1/0.3
Match, wood, stick including flare up	10/3
Grinding metal	IAD

Notes:

- IAD = Immune at Any Distance.
- All sources are chopped from 0–20Hz.

Table 4: Welding Immunity Distance

Sensitivity	Detection Range (ft/m)	Immunity Distance (ft/m)
10	33/10	>10/3
20	65/20	>15/5
30	100/30	>20/7
40	140/43	>33/10

4 Operation

➤ In this chapter...

<i>Visual Indications</i>	<i>page 25</i>
<i>Output Signals</i>	<i>page 26</i>
<i>Detector Mode Setup</i>	<i>page 28</i>
<i>Built-In-Test</i>	<i>page 30</i>

4.1 Visual Indications

One 3-color LED-indicator is located in the detector front window.

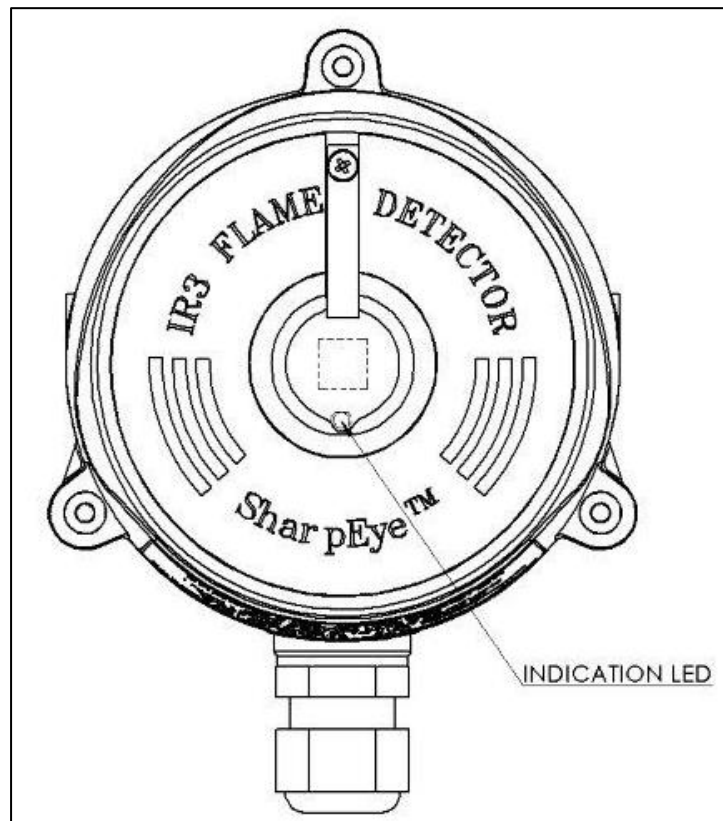

Figure 3: Indicator LEDs

The LEDs are described in Table 5.

Table 5: 20/20MPI Status

Detector Status	LED color	LED mode
Fault, BIT Fault	Yellow	4Hz flashing
Normal	Green	1Hz flashing
Warning	Red	2Hz flashing
Alarm	Red	Constant

4.2 Output Signals

The detector controls the following outputs:

- Model 20/20MPI-R:
 - Alarm Relay
 - Fault Relay
 - RS-485
- Model 20/20MPI-M:
 - 0–20mA Stepped Source Configuration
 - RS-485

The detector can be in one of the following states:

Table 6: 20/20MPI Output Signals

Detector Status	Description
Normal	The detector is functioning normally.
BIT	The detector performs a Built-In-Test.
Warning	Fire detected – warning alarm (pre-alarm) state
Alarm	Fire detected – fire alarm state
Latched Alarm (Optional)	The alarm outputs are latched due to the detection of a fire that has already been extinguished.
BIT Fault	A fault is detected during BIT sequence. The detector will continue to detect fire if the alarm conditions occur.
Fault	A fault is detected when the power supply is too low or during a software fault.

In each state, the detector activates different outputs, as specified in Table 7.

Table 7: Detector State with Output Signals

Detector State	Color LED	Flashing LED	Alarm Relay ¹	Fault Relay ¹	0–20mA Output ²
Normal	Green	1Hz	Off	On	4mA
Warning	Red	2Hz	Off	On	16mA
Alarm ³	Red	Constant	On	On	20mA
Latch ⁴	Red	Constant	On	On	20mA
BIT Fault ⁵	Yellow	4Hz	Off	Off	2mA
Warning at BIT Fault	Red	2Hz	Off	Off	16mA
Alarm at BIT Fault	Red	Constant	On	Off	20mA
Fault	Yellow	4Hz	Off	Off	0mA

Notes:

- 1 Alarm and fault relay refer to Model 20/20MPI-R.
- 2 0–20mA output refers to Model 20/20MPI-M.
- 3 The alarm outputs are activated as long as the alarm conditions are present.
- 4 The alarm state can be latched (optional) according to a programmable function.
- 5 The detector is in its BIT Fault state until it has passed a successful BIT and stops approximately 3 seconds after the fire is no longer detected.

4.2.1 Optional Latching

The detector has an optional latched alarm output capability, which operates according to the programmable function. If selected, upon detection of a fire, the detection signal is latched until manually reset by disconnecting the power supply. Latching affects the alarm relay, 0–20mA output, and the alarm LED.

4.2.2 Built-In-Test

When the programmable function alarm BIT at Yes is successful, the 0–20mA output provides 20mA for 3sec.

4.3 Detector Mode Setup

4.3.1 Detector Setting

Refer to *Detector Default Setup* on page 30 for default factory settings.

The detector incorporates several functions that can be set by the customer using SPECTREX host software, which is supplied with each detector shipment. Please refer to *Manual TM768050* for programming instructions. The host software enables you to change functions as described in *Detector Functions* on page 28.

4.3.2 Detector Functions

4.3.2.1 Sensitivity Ranges

The detector offers 4 sensitivity settings. The settings refer to the gasoline fire of 1ft² from 33ft/10m – 140ft/43m. Detection distances for other fuels vary.

4.3.2.2 Alarm Delay

The detector is equipped with an alarm delay option, which provides programmable time delays of 0–30 seconds with 8 fixed settings:

- 0 seconds
- Anti-flare
- 3 seconds
- 5 seconds
- 10 seconds
- 15 seconds
- 20 seconds
- 30 seconds

When an alarm (detection) level condition is encountered, the detector delays the execution of the alarm output's relay by the specified period of time. The detector then evaluates the condition for 3 seconds. If the alarm level is still present, the alarm outputs are activated. If this condition no longer exists, the detector returns to its standby state. The alarm delay option affects the alarm relay and the 0–20mA output. The LED indicates warning level during the delay time only if the fire conditions exist.

Anti-Flare

Anti-flare mode is selected to prevent false alarms in locations where fast flares may be present. The time delay for a fire alarm in this mode is from 2.5–15 seconds, and is usually less than 10 seconds.

Table 8: Time Delay

Delay (seconds)
0
A (anti-flare)
3 (default)
5
10
15
20
30

Note: The FM approval does not allow use of 20 and 30 second setting delay.

4.3.2.3 Function Setup

You can select the desired mode of operation by means of the host.

Table 9: Function Setup

	Name	Yes	No
1	Alarm Latch	Alarm latching enabled	Alarm latching disabled (default)
2	Automatic BIT	Automatic BIT (default)	No BIT

4.3.2.4 Addresses Setup

Refer to *TM 768050* for instructions for defining the addresses of the detectors.

The detector provides up to 247 addresses (from 1 to 247) that can be used with the RS-485 communications link.

4.3.3 Detector Default Setup

The detector has 5 functions that can be programmed according to the customer requirement at the factory or at the customer facility using the software host. Table 10 lists the standard setup (default) that the detector is programmed with if there are no specific requirements.

Table 10: Default function set up

Detector Default Setup:	20/20MPI-R	20/20MPI-M
Sensitivity	20	20
Delay	3	3
Alarm Latch	No	No
Automatic BIT	Yes	Yes
Alarm BIT	No	No

4.4 Built-In-Test

4.4.1 General

The detector's Built-In-Test (BIT) checks the following:

- Electronics circuitry
- Sensors
- Window cleanliness

The detector can be set to perform the BIT as:

- Automatically
- or
- no BIT

4.4.2 Principles

If the result of a BIT is the same as the current status of the detector (normal or BIT fault), the detector's status is left unchanged. If the result of a BIT differs from the current status of the detector, the detector's status is changed (from normal to BIT fault or from BIT fault to normal).

Note: In BIT fault status, the detector can continue to detect a fire.

4.4.3 Automatic BIT

4.4.3.1 Automatic BIT

The detector automatically performs a BIT every 15 minutes.

A successful BIT does not activate any indicator.

- The fault relay remains closed (normal) in Model 20/20MPI-R.
- The LED continues to flash (1Hz) at green.
- The 0–20mA output continues to indicate 5mA in model 20/20MPI-M.

An unsuccessful BIT sequence activates the following:

- The fault relay opens in model 20/20MPI-R.
- 0–20mA output indicates BIT fault (2mA) in model 20/20MPI-M.
- The LED flashes (4Hz) at yellow.
- BIT procedure is performed every 1 minute.

5 Technical Specifications

➤ **In this chapter...**

<i>Electrical Specifications</i>	<i>page 33</i>
<i>Approvals</i>	<i>page 34</i>
<i>Mechanical Specifications</i>	<i>page 34</i>
<i>Environmental Specifications</i>	<i>page 35</i>

5.1 Electrical Specifications

- **Operating Voltage:** 18–32VDC
- **Power Consumption:**
 - Max. 16mA in standby
 - Max. 40mA in alarm
- **Electrical Outputs**
 - Dry Contact Relays:

Table 11: Contact Ratings

Relay Name	Type	Normal position	Maximum Ratings
Alarm	SPST	N.O.	2A at 30VDC
Fault *	SPST	N.C.	2A at 30VDC

* The fault relay is normally energized and the contact is closed during normal operation of the detector. The contact is open at fault condition or low voltage.

- 0–20mA current output:
 - The 0–20mA is source option only.
 - The maximum permitted load resistor is 600ohm.

Table 12: 0–20mA Current Output

State	Output
Fault	0 + 0.5mA
Bit Fault	2mA±10%
Normal	4mA±10%
Warning	16mA±5%
Alarm	20mA±5%

- **Communications Network:**

The detector is equipped with an RS-485 communications link that can be used in installations with computerized controllers. The communications protocol is Modbus compatible.

- This protocol is a standard and widely used.
- It enables continuous communication between a single standard Modbus controller (master device) and a serial network of up to 247 detectors.
- It enables connection between different types of SPECTREX detectors or other Modbus devices to the same network.

5.2 Approvals

Functional approvals:

- EN54-10, page 34
- FM, page 34

5.2.1 EN54-10

The 20/20MPI Flame Detector is certified to EN54-10 and CPD.

The detector has been tested and approved per EN54-10 by VdS. This test includes functional test, environmental test, EMI/EMC test, and software check. For more details see VdS Report Numbers BMA 13107 and BMA 13108.

5.2.2 FM

The 20/20MPI Flame Detector is certified to FM Functionality per FM3260 Fuel Test Response including: Gasoline, N-Heptane, Diesel, JP5, Kerosene, Ethyl, Alcohol 95%, IPA, Methanol, Methane, LPG, Polypropylene, and Paper. For more details see *FM Report Project ID# 3047835*.

5.3 Mechanical Specifications

- **Enclosure:** Polycarbonate
- **Functional Test:** FM functional test per FM3260
- **Water and dust tight:** IP55 per EN 60529
- **Electronic Modules:** Conformal coated.
- **Electrical connection:** M20 Gland Connection
- **Dimensions:** 4.7" x 2.9" diameter / 119 x 74mm
- **Weight:**
 - Detector: 10.6oz/300g
 - Tilt Mount: 2.5oz/70g

5.4 Environmental Specifications

Electromagnetic Compatibility (EMC)

This product is in conformance with EMC directive 89/336/EC.

- Radiated Emission EN61000-6-3
- Conducted Emission EN61000-6-3
- Radiated Immunity EN50130-4
- Conducted Immunity EN50130-4
- ESD EN50130-4
- Burst EN50130-4
- Surge EN50130-4

6 Installation Instructions

➤ In this chapter...

<i>Scope</i>	<i>page 37</i>
<i>General Considerations</i>	<i>page 37</i>
<i>Preparations for Installation</i>	<i>page 38</i>
<i>Detector and Tilt Mount Installation</i>	<i>page 39</i>
<i>Detector Wiring</i>	<i>page 42</i>
<i>Wiring Function</i>	<i>page 42</i>
<i>Protective Cover Installation</i>	<i>page 43</i>
<i>Operation Mode</i>	<i>page 44</i>

6.1 Scope

The SharpEye Model 20/20MPI is a self-contained optical flame detector designed to operate as a stand-alone unit directly connected to alarm systems or automatic fire extinguishing systems. The detector can be a part of a more complex system where many detectors and other devices are integrated through a common control unit. This chapter does not attempt to cover all of the standard practices and codes of installation. Rather, it emphasizes specific points of consideration and provides some general rules for qualified personnel. Wherever applicable, special safety precautions are stressed.

6.2 General Considerations



Important: The detector should be aimed toward the center of the detection zone and have a completely unobstructed view of the protected area. Whenever possible, the detector face should be tilted down at a slight angle to prevent the accumulation of dust and dirt. Do not start an installation unless all conceivable considerations regarding detector location have been taken into account.

To ensure optimal performance and an efficient installation, the following guidelines should be considered:

- Sensitivity

To determine the level of sensitivity, the following issues should be considered:

- Size of fire at determined distance to be detected.
- Type of flammable materials.

- Spacing and Location

The number of detectors and their locations in the protected area are affected by:

 - Size of the protected area
 - Sensitivity of the detectors
 - Obstructed lines of sight
 - Cone of view of the detectors
- Environment
 - Dust, snow, or rain can reduce the detectors sensitivity and require more maintenance activities.
 - The presence of high intensity flickering of IR sources may affect sensitivity.

6.3 Preparations for Installation

Installation should comply with NFPA 72E or local regulations, as applicable to flame detectors. The detectors can be installed with the use of general-purpose common tools and equipment.

- 1** The detector package includes detector assembly, tilt mount P/N 768004, protective cover P/N 768005 and 3mm Hex Key.

Since this detector is for indoor applications only, do not assemble the protective cover unless it is necessary.
- 2** Verify the appropriate Purchase Order. Record the Part Number (P/N) and the Serial Number of the detectors and the installation date in the appropriate logbook.
- 3** Open the container package prior to detector installation and visually inspect the detector.
- 4** Verify that all components required for the detector installation are readily available before commencing the installation. If the installation is not completed in a single session, secure and seal detectors and conduits.
- 5** For wiring, use color-coded conductors or suitable wire markings or labels.

16–22AWG / 0.4–1.4mm² wires may be used for site wiring. The selection of wire gauge should be based on the number of detectors used on the same line and the distance from the control unit, in compliance with specifications.

6.4 Detector and Tilt Mount Installation

Refer to Figure 4 and Figure 5.

- 1 Unpack the detector. The package includes:
 - Detector Assembly P/N 768001 - 20/20MPI-R or 20/20MPI-M
 - Tilt Mount P/N 768004 including screw M4 X 12" for installation of the detector
 - Protective Cover P/N 768005 (optional use where needed)
 - 3mm Hex Key
- 2 Place the tilt mount (Item 2) in its designated location and secure it with 3 fasteners through 3 holes 5.4mm in diameter (Figure 4).

Note: Skip this step if the tilt mount is already installed. Also, detector removal for maintenance purpose does not require tilt mount removal.
- 3 Place the detector, with its gland pointing down, on the holding plate of the tilt mount (Item 3). Secure the detector by 1 holding screw M4 x 12" to the tilt mount. Use 3mm Hex Key for M4 screw (see Item 4 on Figure 5).
- 4 Release the locking screws (Items 5 and 6 in Figure 5) in such a way that allows rotating the detector. Point the detector towards the protected area and make certain that the view of the area is unobstructed. Secure the detector in that position by tightening the locking screws (Items 5 and 6) on the tilt mount. (Make sure the detector is in the right position.)

The detector is now correctly located, aligned, and ready to be connected to the system.

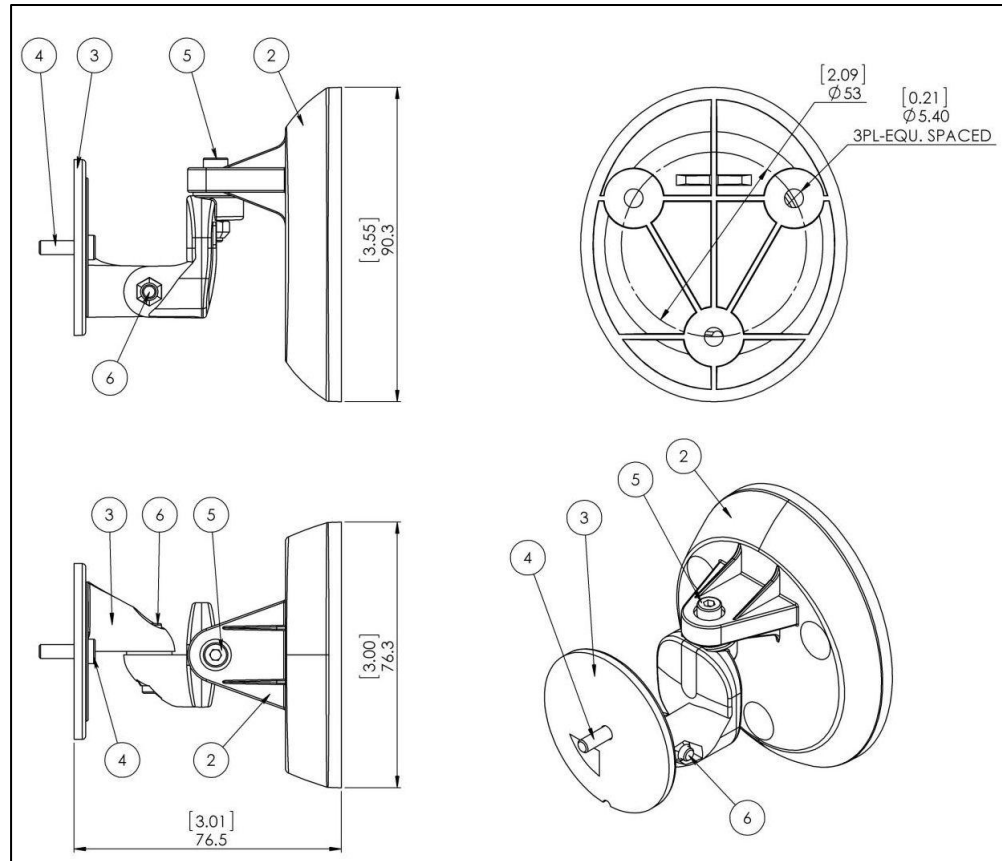

Figure 4: Tilt Mount Assembly - Outline Drawing

Number	Description
1	Mounting Plate
2	Holding Plate
3	Holding Screw
4	Alignment Screw
5	Alignment Screw

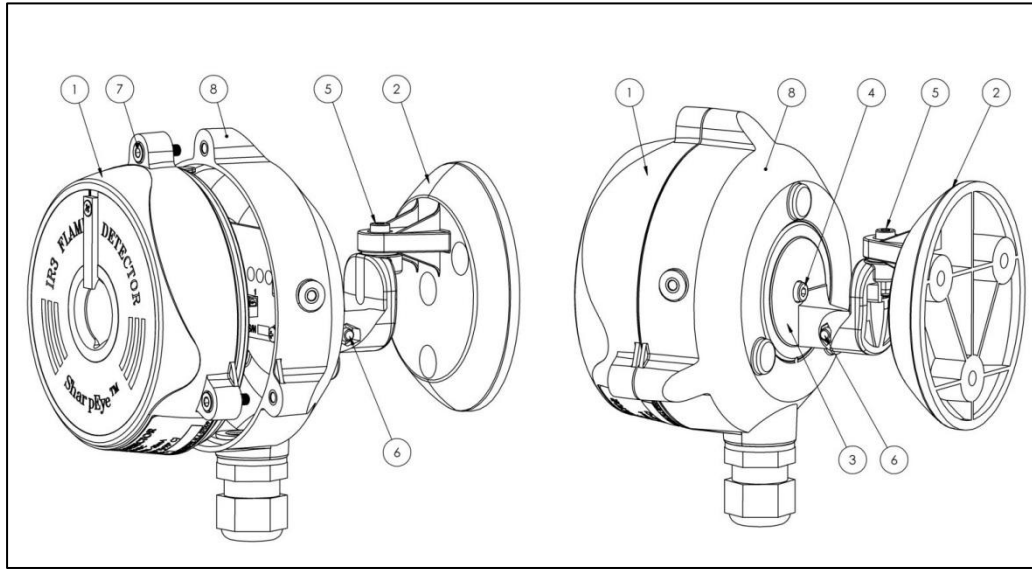

Figure 5: IR3 Detector and Tilt Mount Assembly

Number	Description
1	Detector Housing
2	Mounting Plate
3	Holding Plate
4	M4 X 12 Hex Screw
5	M4 x 20 Hex Screw
6	M4 x 16 Hex Screw
7	M4 x 13 Hex Captive Socket Head Screw
8	Connection Box Assembly

6.5 Detector Wiring

- 1 Choose the wiring configuration according to *Typical Wiring Configurations* on page 55.
- 2 Connect the wire to the required terminal according to your wiring.
 - a Remove the 3 socket-head captive screw M4-13 that secure the detector housing (Item 1 on Figure 5) to its back cover (Item 8) using the 3mm Hex Key. Pull the detector housing from its connection box.
 - b Make sure that the cover remains attached to the detector swivel mount.
 - c Pull the cable through the cable gland.
 - d Connect the wires to the required terminals according to the wiring diagram (see *Typical Wiring Configurations* on page 55).
 - e Verify that the wiring is wired according to the wiring diagram. Improper connection may damage the detector.
 - f Check the wiring for secure mechanical connection and press the wires neatly against the terminal board to prevent them from interfering while closing the detector's housing.
 - g Return the detector housing to the connection box and secure it with the 3 socket-head screws.

6.6 Wiring Function

Refer to Figure 6 and Figure 7.

The following describes the function of each electrical wire of the detector:

- Power Supply
 - Terminal # 1 or red wire - used for input power
 - Terminal # 2 or black wire - used for return
- Fault Relay for Model 20/20MPI-R

The fault output is a N.C. SPST contact relay:

 - Terminal # 7 or brown wire
 - Terminal # 8 or light blue wire

The contact is normally energized closed when the detector is in its normal operational condition.
- Alarm Relay for Model 20/20MPI-R

The alarm output is a N.O. SPST contact relay.

 - Terminal # 5 or orange wire
 - Terminal # 6 or violet wire

- 0–20mA Output for Model 20/20MPI-M
This output is used for stepped 0–20mA current output:
Terminal # 8 output (+) refers to terminal 2 RTN. See *Typical Wiring Configurations* on page 55 for more details.
- RS-485
This output is used for a communications network as specified in *Typical Wiring Configurations* on page 55.
 - Terminal # 3 RS-485 (+)
 - Terminal # 4 RS-485 (-)

6.7 Protective Cover Installation

The protective cover need only be used if required at a specific location, such as protection from water drips, high dust, etc.

After wiring the detector, place the protective cover as in Figure 6. Screw the Hex screw using the 3mm Hex Key.

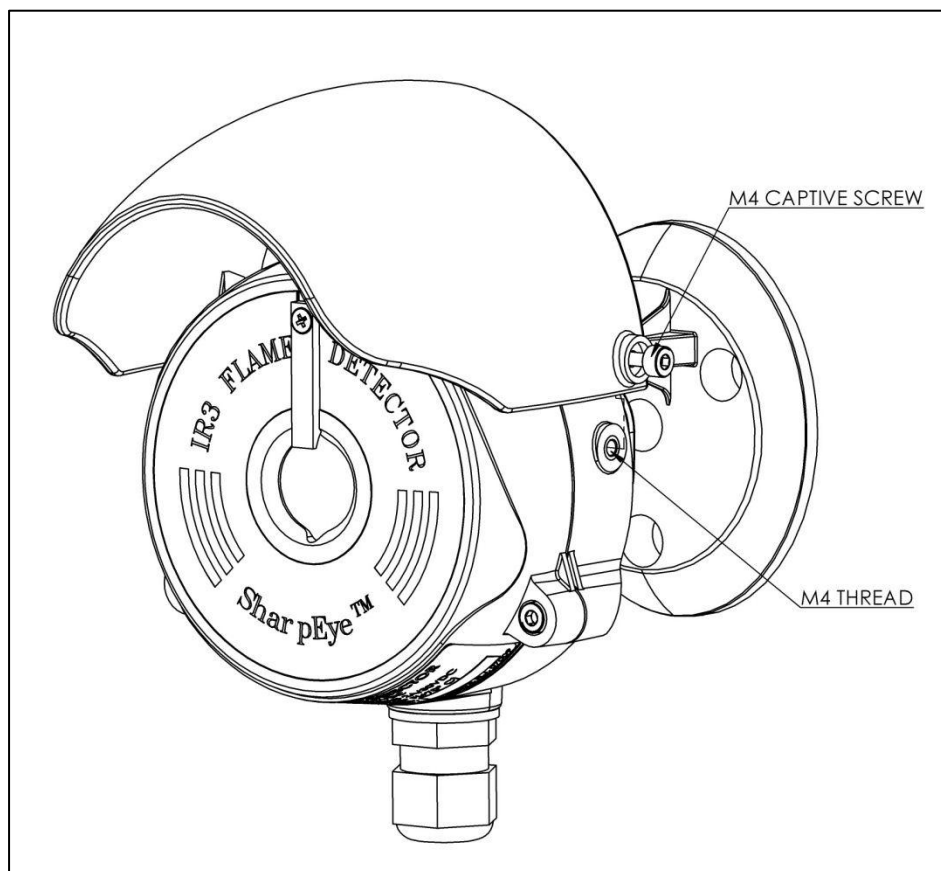

Figure 6: Protective Cover

6.8 Operation Mode

The detector is supplied with a default function setup as follows:

Table 13: Detector Default Setup

Function	20/20MPI-R	20/20MPI-M
Sensitivity	20	20
Delay	3	3
Alarm Latch	NO	NO
Automatic BIT	YES	YES

You can reprogram the function setup through RS-485 using a PC with a SPECTREX host, or using a handheld unit. Refer to *Manual TM 768050* for instructions.

6.8.1 Programmable Function

Modes of operation are programmable with a PC or handheld unit according to the selection table in *Detector Functions* on page 28.

6.8.2 Address

The detector is capable of acting as an addressable device. The detector provides 247 (1–247) addresses, which can be used by the RS-485 communications link.

6.8.3 Alarm Delay

An alarm delay may be required for certain applications. The detector has an alarm delay that permits time delays from 0, anti-flare, 3, 5, 10, 15, 20, and 30 seconds respectively. The delay can be defined by the RS-485.

Refer to *Manual TM 768050* for further instructions.

7 Operating Instructions

➤ In this chapter...

<i>Power Up</i>	<i>page 45</i>
<i>Reset</i>	<i>page 46</i>
<i>Functional Testing</i>	<i>page 46</i>
<i>Safety Precautions</i>	<i>page 47</i>

This chapter describes how to power up and test the detector. It also includes some very important safety checks that you should make before operating the detector.

7.1 Power Up

➤ To power up the detector:

- 1 Apply power and wait approximately 60 seconds for the automatic self-test of the detector.

Note: Applying power initiates the following sequence:

- 4Hz LED flashes yellow and the BIT is executed
- If successful, the 1Hz LED flashes green, and the FAULT relay contacts close.

- 2 **Wiring Inspection:** If a short-circuit or line discontinuity exists, fault indications appear on the control unit display panel. Check your wiring.

The detector is in fault state when the supply voltage drops under 16.5V. The detector status returns to normal when the supply voltage is above 17.5V.

- 3 **Detector Inspection:** Visually inspect the viewing window of the detector. It should be clean and clear. Verify the following:

- 1Hz LED flashes green
- Alarm relay is N.O.
- Fault relay is N.C.
- 0–20mA output is 4mA

- 4 If any of the outputs or indications is different from the description in step 3, see *Troubleshooting* on page 50.

The flame detector is now ready for functional testing.

7.2 Reset

Note: This is available only when the optional latched alarm has been selected.

To reset a detector when in it is in alarm state, disconnect the power.

7.3 Functional Testing

The detector can be tested for proper functioning using the Flame Simulator Model FS-1100.

7.3.1 Testing with Flame Simulator Model FS-1100

Refer to *Flame Simulator FS-1100* instructions on page 59.

This test simulates an exposure of the detector to a real fire condition. The detector is exposed to radiation at the required detection level. As a result, the detector will generate a fire alarm signal.



Important: If the detector is exposed to a flame simulator, the alarm relay and 0–20mA will be activated during the simulation. Therefore, automatic extinguishing systems or any external devices, which may be activated during this process, must be disconnected.

➤ **To test with Flame Simulator Model FS-1100:**

- 1 (If the detector is on, skip this step.)

Apply power to the system and wait up to 60 seconds for the detector to return to the normal state.

The 1Hz LED flashes green.

Aim the SPECTREX Flame Simulator Model FS-1100 at the target point of the detector (see Figure 12), in such a way that the radiation emitted by it is facing directly towards the detector. (See *Flame Simulator FS-1100* on page 59)

- 2 Press the operation button once. After few seconds, the following occurs:
 - The LED lights up red constantly for a few seconds.
 - The 0–20mA output turns to 20mA for a few seconds, and then returns to 4mA.
 - The alarm relay also turns on.

This completes the installation procedure. The detector and system are now ready for operation.

7.4 Safety Precautions

After power-up, the detector requires almost no attention in order to function properly, but the following should be noted:

- Follow the instructions in the manual and refer to the drawings and specifications issued by the manufacturer.
- Do not expose the detector to radiation of any kind unless required for testing purposes.
- Do not open the detector housing while the power is on.
- Do not touch internal parts other than the 3 functional switches. Interference with internal circuits may impair detector performance and will invalidate SPECTREX's warranty.
- Disconnect external devices, such as automatic extinguishing systems, before carrying out any maintenance.

8 Maintenance Instructions

➤ **In this chapter...**

<i>Maintenance Instrumentation and Personnel</i>	<i>page 49</i>
<i>Preventive Maintenance Procedures</i>	<i>page 49</i>
<i>Periodic Maintenance Procedures</i>	<i>page 50</i>
<i>Maintenance Records</i>	<i>page 50</i>
<i>Troubleshooting</i>	<i>page 50</i>

This section describes the basic maintenance steps that should be taken to keep the detector in good working order. In addition, it describes possible faults in detector operation and indicates corrective measures.

Ignoring these instructions may cause problems with the detector and may invalidate the warranty. Whenever a unit requires service, please contact Rosemount Inc. or an authorized distributor for assistance.

8.1 Maintenance Instrumentation and Personnel

The detector's maintenance requires ordinary tools and suitably qualified personnel, who should be familiar with local codes and practices.

8.2 Preventive Maintenance Procedures

The detector must be kept as clean as possible. The viewing window and the reflector flame detector must be cleaned on a periodic basis. The frequency of cleaning operations depends upon the environmental conditions and specific applications. The fire detection system designer will give his recommendations.

➤ **To clean the detector:**

- 1 Disconnect power to the detector before beginning any maintenance including lens cleaning.
- 2 To clean the detector viewing window and reflector use water and detergent, and rinse with clean water.

Where dust, dirt, or moisture accumulate on the window, first clean with a soft optical cloth and detergent, and then rinse with clean water.

8.3 Periodic Maintenance Procedures

In addition to preventive cleaning and maintenance, the detector should be functionally tested every 6 months. This test should also be carried out if the detector has been opened for any reason.

8.3.1 Power-Up Procedure

Perform power-up procedure every time power is restored to the system. Follow the instructions in *Power Up* on page 45.

8.3.2 Functional Test Procedure

Perform a functional test of the detector as described in *Functional Testing* on page 46.

8.4 Maintenance Records

It is recommended that maintenance operations performed on a detector are recorded in a logbook. The record should include the following:

- Installation date
- Contractor
- Serial and tag number
- Entries for every maintenance operation performed, including the description of the operation, date, and personnel ID.

If a unit is sent to SPECTREX or a distributor for service, a copy of the maintenance records should accompany it.

8.5 Troubleshooting

8.5.1 Fault Indication

➤ **To identify the fault indication:**

- 1 Check power supply for correct voltage, polarity and wiring.
- 2 Check detector window and reflector for cleanness. If necessary clean the window as indicated in *Periodic Maintenance Procedures* on page 50, and then repeat the test.
- 3 Disconnect the power supply to the system and check the detector's internal wiring.
- 4 Reconnect the power supply and wait approximately 60 seconds. Repeat the test. If the 4Hz LED still flashes yellow, the unit requires service.

8.5.2 False Alarm or Warning Indication

➤ **To identify the false alarm or warning indication:**

- 1 Disconnect the power supply from the system and check the internal wiring.
- 2 Reconnect the power supply and wait approximately 60 seconds. If the indication remains, the unit requires service.

8.5.3 RS-485 Communications Network

Using the RS-485 network capability of the IR3 detector and control software, you can connect up to 32 detectors in an addressable system with only 4 wires (2 for power and 2 for communication). Using repeaters, the number of detectors can be much larger (32 detectors for each repeater) up to 247 on the same 4 wires. When using the RS-485 network, you can read each detector status (FAULT, WARNING, ALARM) and to initiate a BIT for each detector individually.

For more details, contact SPECTREX.

Appendix

A Typical Wiring Configurations

➤ **In this appendix...**

Wiring Terminal 20/20MPI-R *page 55*

Wiring Terminal 20/20MPI-M *page 56*

A.1 Wiring Terminal 20/20MPI-R

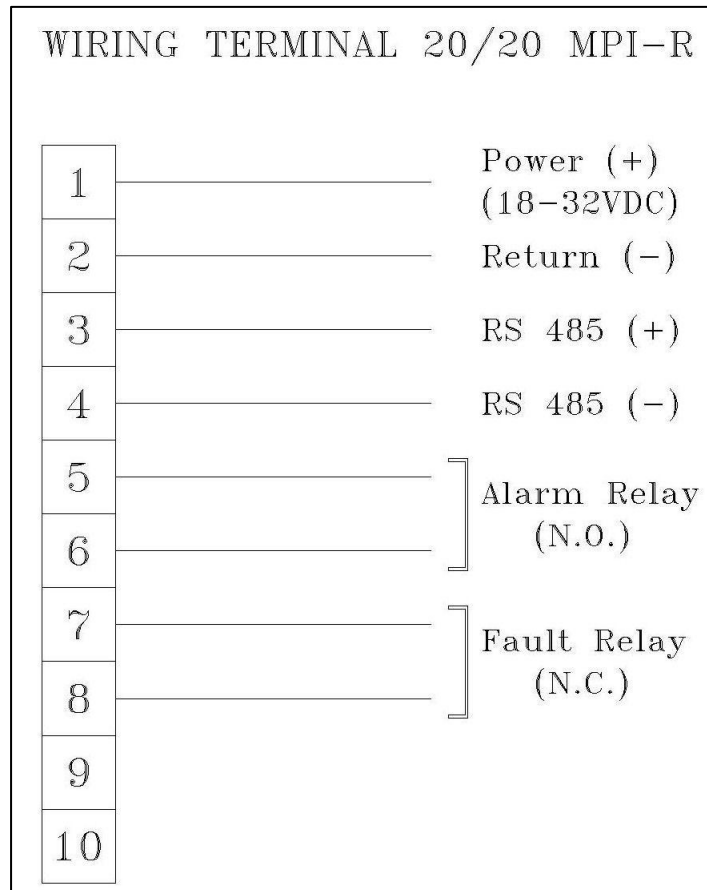

Figure 7: Wiring Terminal 20/20MPI-R

A.2 Wiring Terminal 20/20MPI-M

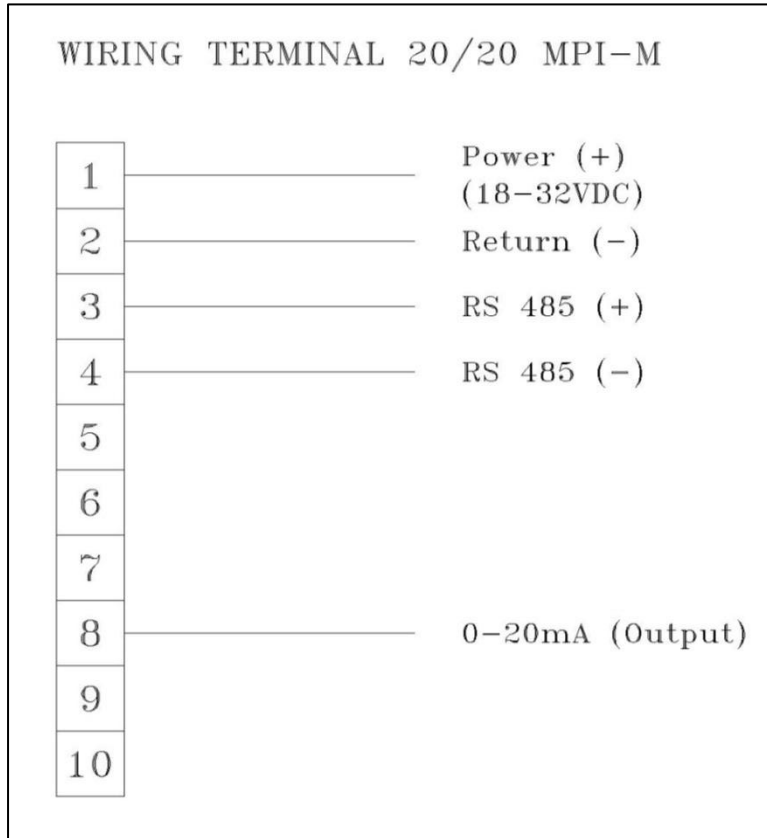

Figure 8: Wiring Terminal 20/20MPI-M

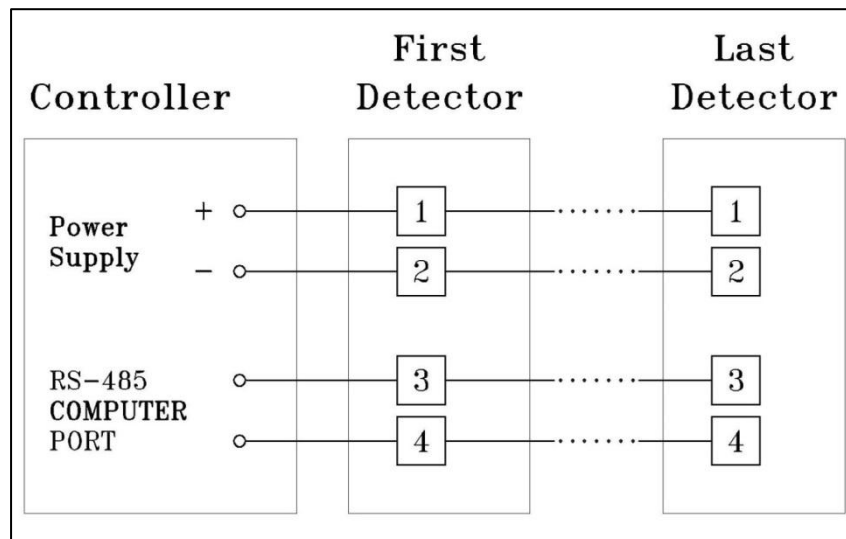

Figure 9: RS-485 Networking

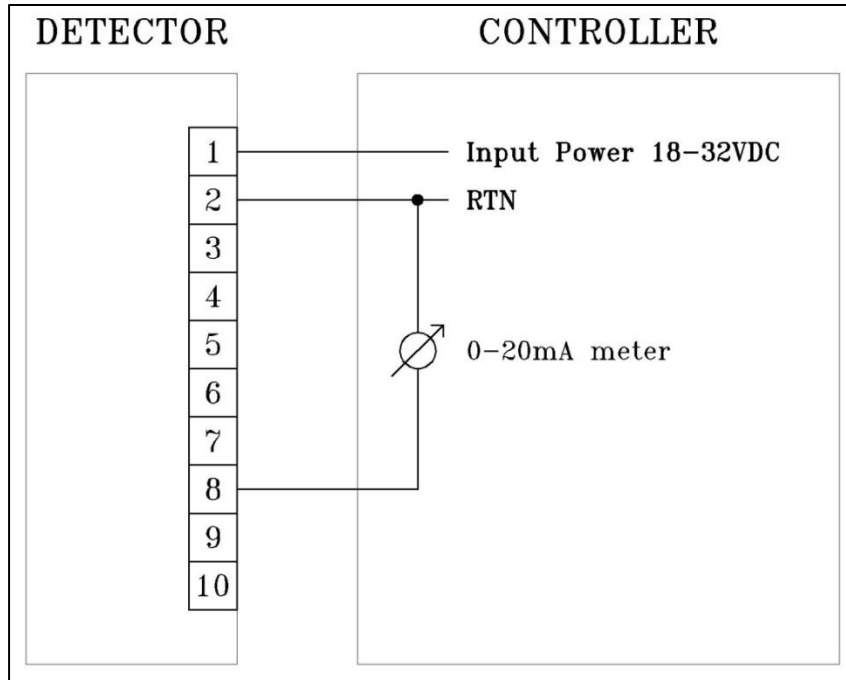

Figure 10: 0-20mA Source (3-Wire) - Model 20/20MPI-M

Note: The detectors are 0-20mA source only configuration.

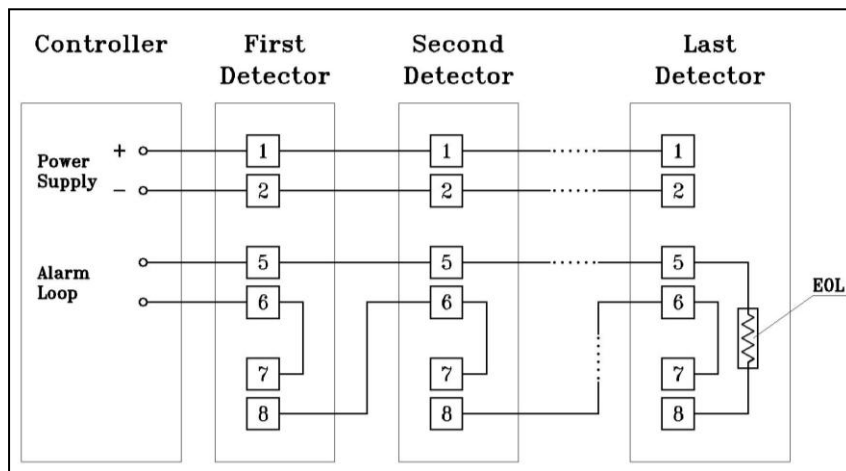

Figure 11: Typical Wiring for 4 Wire Controllers – Model 20/20MPI-R

B Flame Simulator FS-1100

➤ **In this appendix...**

<i>Description</i>	<i>page 59</i>
<i>Ordering Information</i>	<i>page 60</i>
<i>Unpacking</i>	<i>page 60</i>
<i>Operating Instructions</i>	<i>page 62</i>
<i>Range</i>	<i>page 62</i>
<i>Charging the Battery</i>	<i>page 62</i>

B.1 Description

The Flame Simulator FS-1100 is designed specifically for use with SharpEye Flame Detectors. The flame simulator emits IR radiation in a unique sequential pattern corresponding to and recognizable by the detector as fire, which allows the detectors to be tested under simulated fire conditions without the associated risks of an open flame.



Figure 12: Flame Simulator

B.2 Ordering Information

The P/N of the Flame Simulator Kit is 380114-1.

The kit is supplied in a carry case that includes:

- Flame Simulator FS-1100
- Charger
- Tool Kit
- Technical Manual *TM380002*

B.3 Unpacking

Verify that you have received the following contents:

- Delivery form
- Flame simulator with integral battery
- Battery charger
- Tool keys
- User manual
- FAT forms
- EU declaration
- Storage case

B.4 Operating Instructions

Warning: Do not open the flame simulator to charge the batteries or for any other reason in a hazardous area.

Caution: The following test simulates a real fire condition and may activate the extinguishing system or other alarms. If activation is not desired, disconnect/inhibit them before the test and reconnect after the simulation.

➤ **To simulate a fire:**

- 1 Verify you are at the correct distance from the detector according to the type of detector and the detector sensitivity.
- 2 Using the mechanical sight, aim the flame simulator toward the target point of the detector.
- 3 Push the activate button, and then use the laser spot for fine adjustment toward the center of the detector.
- 4 Keep the simulator aimed at the detector for up to 50 seconds, until you trigger an alarm.
- 5 Wait 20 seconds before repeating the test.

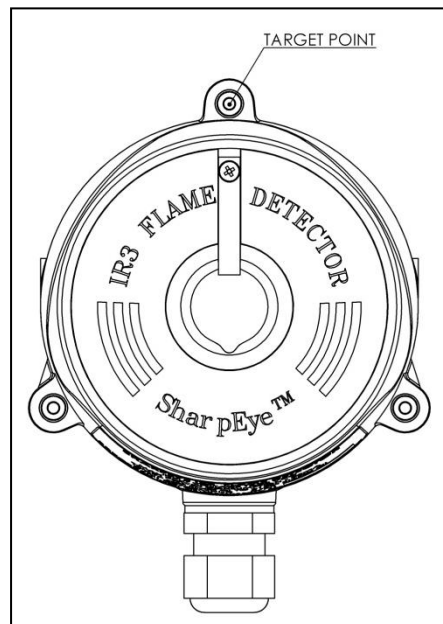

Figure 13: Mini IR3 Detector Target Point

B.5 Range

Table 14: Sensitivity Ranges

Sensitivity (ft/m)	Range (ft/m)	Extended Range (ft/m)
33/10	2.3/0.7	-
65/20	4/1.2	8.2/2.5
100/30	6.6/2	13.2/4
132/40	10/3	20/6

* At extreme temperatures - 15% Max. Reduction in range

B.6 Charging the Battery

The flame simulator uses lithium/ion batteries as a rechargeable power source. When the batteries are fully charged, the simulator operates at least 1,000 times without having to be recharged. The simulator will not operate when the voltage from the batteries is lower than the required operational level.

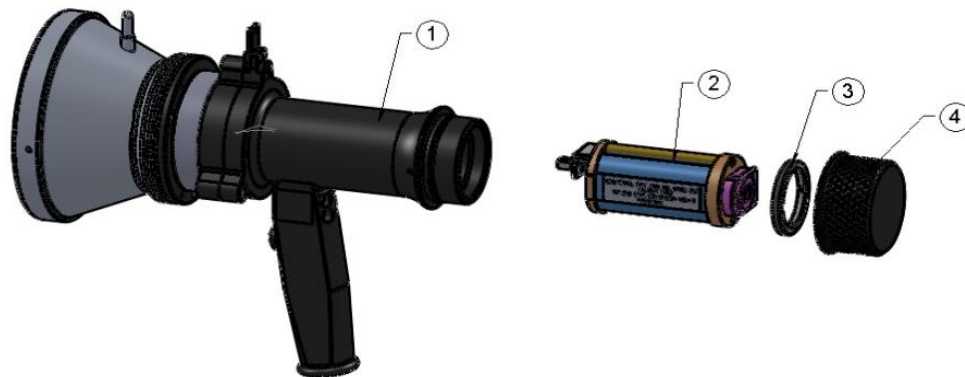

1	Simulator
2	Battery Pack
3	Locking Disc
4	Back Cover

Figure 14: Flame Simulator Battery Replacement

➤ **To charge the battery:**

- 1 Place the flame simulator on a table in a safe area, not exceeding 104°F/40°C.
- 2 Release the locking screw.
- 3 Unscrew the battery back cover (Item 4) counterclockwise.
- 4 Unscrew the locking disc (Item 3) clockwise.
- 5 Pull out the battery from the flame simulator.

- 6 Connect the battery to the charger. Verify that the charger is the one supplied with the flame simulator Model FRIWO MPP15 with maximum charging voltage of 16.8V (4.2V x 4), and with a maximum current of 700mA.
- 7 Charge for a maximum of 2–3 hours, until the green LED on the charger turns on.
- 8 Disconnect the charger.
- 9 Insert the battery into the flame simulator.
- 10 Screw on the locking disc (Item 3).
- 11 Screw on the back cover (Item 4).
- 12 Lock the back cover with the locking screw.

B.7 Battery Replacement

➤ **To replace the battery:**

- 1 Place the flame simulator on a table in a safe area, not exceeding 104°F/40°C.
- 2 Release the locking screw.
- 3 Unscrew the battery back cover (Item 4) counterclockwise.
- 4 Unscrew the locking disc (Item 3) clockwise.
- 5 Pull out the battery from the flame simulator.
- 6 Insert the new battery pack in the simulator housing. Use only SPECTREX battery pack, P/N 380004.
- 7 Screw on the locking disc (Item 3).
- 8 Screw on the back cover (Item 4).
- 9 Lock the back cover with the locking screw.

Note: For more information refer to *TM 380002*.

B.8 Technical Specifications

General	Temperature Range: -4°F to +122°F / -20°C to +50°C Vibration Protection: 1g (10-50Hz)
Electrical	Power: 14.8V (4 X 3.7V rechargeable lithium-ion batteries) Max. Current: 4A Battery Capacity: 2.2AH Charging Time: 2A at 2hr
Physical	Dimensions: 230 x 185 x 136 mm Weight: 5.5lb/2.5kg Enclosure: aluminum, heavy duty copper free, black zinc coating Explosion proof enclosure: ATEX & IECEX Ex II 2 G D Ex d ib op is IIB +H2 T5 Gb Ex ib op is tb IIIC T135°C Db -20°C to +50°C / -4°F to +122°F

EMI Compatibility

Table 15: Immunity Tests

Immunity Tests		
Title	Basic Standard	Level to be tested
Electrostatic Discharge (ESD)	IEC 61000-4-2	6kV/8kV contact/air
Radiated Electromagnetic Field	IEC 61000-4-3	20V/m (80MHz-1GHz) 10V/m (1.4-2GHz) 3V/m (2.0-2.7GHz)
Conducted Disturbances	IEC 61000-4-6	10Vrms (150kHz-80MHz)
Immunity to Main Supply Voltage Variations	MIL-STD-1275B	

Table 16: Emission Tests

Emission Tests			
Title	Basic Standard	Level to be Tested	Class
Radiated Emission	IEC 61000-6-3	40 dbuv/m (30-230MHz), 47 dbuv/m (230MHz-1GHz)	Like Class B of EN 55022

Technical Support

For technical assistance and support, contact:



8200 Market Blvd
Chanhassen, MN 55317
USA

Phone: +1 (973) 239 8398

Fax: +1 (973) 239 7614

Email: spectrex@spectrex.net

Website: www.spectrex.net

Your Local SPECTREX Office:

Texas (USA)

Mr. Jay Cooley, Regional Sales Manager:
16203 Park Row, Suite 150
Houston, Texas 77084
USA

Phone: +1 (832) 321 5229

Email: jay.cooley@emerson.com

Far East

Mr. Deryk Walker, Regional Sales Manager
59 Fen Ji Hu, Danshui
Taipei County 25163
Taiwan (ROC)

Phone: +886 2 8626 2893

Mobile: +886 926 664 232

Email: deryk.walker@emerson.com